

FAIRBANKS®

DELTA SERIES GENERAL PURPOSE BENCH SCALES



Fairbanks' Delta Series are technologically advanced bench scales ideal for virtually any non-washdown, general weighing application.

VERSATILE AND ECONOMICAL

The Delta Series is designed to perform day in and day out in demanding industrial conditions and is rated the most economical general purpose weighing platform on today's market. Delta scales are available in a wide variety of sizes and capacities. A roller-ball top or stainless steel cover is available for most models.

INSTRUMENTATION

Delta Series platforms are compatible with Fairbanks' extensive line of analog indicators. They can also be configured to work with Fairbanks' counting scales. These platforms, however, are not limited to Fairbanks' instrumentation, they're compatible with any manufacturers' analog weighing indicators.

LOW PROFILE

The Delta platform profile is lower than all competing models, making it the choice product for greatly reducing operator fatigue and risk of injury. Platform heights measure from 2.28" to 2.64".

APPLICATIONS

Fairbanks' Delta Series bench scales are designed and engineered with a variety of weighing applications in mind, including:

- General purpose
- Shipping & Receiving
- Batching
- Inventory
- Quality control
- Manufacturing

SPECIFICATIONS

Cable Length	10 foot (platform to instrument)
Overload	300% of rated scale capacity
Excitation voltage (VDC)	10
Rated output (mV/V)	1
Output resistance Ω	1,000
Construction material	Mild steel - all sizes and capacities
Resolution	3,400 divisions maximum commercial
Accessories	Stainless steel platform cover (all models) Roller-ball top (14" x 14", 18" x 18", 24" x 24")
Approvals	NTEP, MC FM approved load cells

DIMENSIONS AND CAPACITIES

Platform Size	Platform Height	Platform Capacity
12" x 12"	2.28"	6, 12 or 25 lbs.
14" x 14"	2.38"	60 or 150 lbs.
18" x 18"	2.64"	100 or 300 lbs.
24" x 24"	2.39", 2.42" & 2.48"*	200, 300 & 500 lbs.

*Height dimension corresponds to respective capacity.

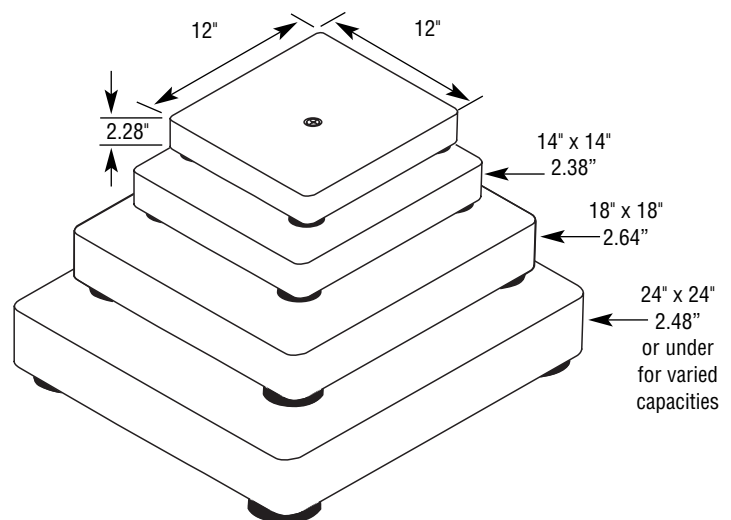

QuickFacts™

Models and specifications subject to change without notice.
© Fairbanks Scales Inc.
www.Fairbanks.com

Call toll-free for the Fairbanks representative nearest you:
(800) 451-4107