

FAIRBANKS®

FB 3000 SOLUTION SERIES NEMA 4X INSTRUMENTS



The FB 3000 NEMA 4X washdown instrument has more connectivity options and data acquisition capabilities than any other scale instrument on the planet. With combined features of both an instrument and PC, the FB 3000 NEMA 4X allows users to program the unit in any computer language or with their own specialized software. It can even connect directly to a company network.

STANDARD FEATURES

- NEMA 4X washdown
- 512 MB internal memory and 40 GB disk drive
- RJ45 Ethernet port
- 10.4" full color, high resolution graphics, display screen
- Touch screen operation
- Plug-and-play networkable via ethernet
- Compatible with network printers
- Embedded Windows® XP Pro
- 20 mA
- 4-20 mA

OPTIONS

- Flash card for backup storage

FUNCTIONS

- GTN weighing — In/Out weighing — Stores Tares — Formattable tickets
- Onboard backup routine — emailed messages — remote accessible
- Instrument drives up to two scales

SPECIFICATIONS

Display	10.4" Color SVGA - 600 x 800
Memory	512 MB RAM (expandable)
Processor	1 GHz
Storage	40 GB (expandable)
SDD Interface	One 50-pin compact Flash socket; flash card is optional
Enclosure	SS NEMA 4X
Device Platform	XP Pro embedded
Outputs	2 USB ports (externally accessible); 1 USB port (internal); 2 Serial ports (internal); 1 RJ45 port for network connection, 100/10 Mbps Ethernet controller (internal); 1 SVGA port (internal); 1 PS2 port (internal); 20 mA (internal); 4-20 mA passive, high resolution (internal)
HID	Touch screen
Number of scales	Up to 2
Battery	Lithium, data retention up to 10 years
Options	Expanded memory
Approvals	NTEP CC# 04-013A1; MC #AM-5552C

DIMENSIONS

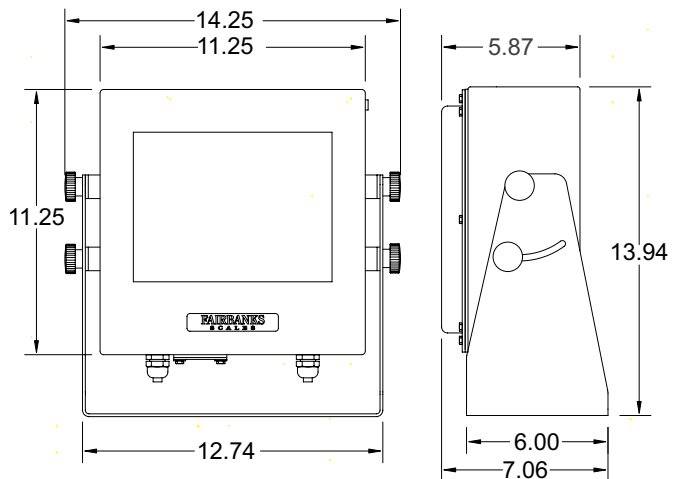

Leasing

Convenient, affordable leasing options available through Fairlease. Ask your Fairbanks sales representative for details.

QuickFacts™

Models and specifications subject to change without notice.
Printed in the USA. © Fairbanks Scales Inc.

Call toll-free for the Fairbanks representative nearest you:

(800) 451-4107

Internet Address: <http://www.Fairbanks.com>

09/07

100436