

Intercomp CS™ 750



Standard Features

- Digital calibration
- Auto shut-off
- 1" LCD digital readout
- Powered by 6 D cell batteries
- Infrared remote control
- Automatic backlight

Approvals



Specifications

RESOLUTION:

20 bit A/D delivers more than 1 million internal counts

CONTROLS:

Zero, On, Off, Backlight

DISPLAY:

1" (25 mm) 5-digit LCD

INDICATORS:

lb/kg

POWER:

(Batteries are not included) six D size disposable alkaline dry cell or rechargeable nickel-cadmium cell Battery life is one year of normal use.

DIMENSIONS:

Control box: 8.5" L x 5" W x 4.25" H
(216 mm L x 127 mm W x 108 mm H)
Lifting eye to hook: 9.5" (241 mm)

ENCLOSURE:

Weatherproof extruded-aluminum case

APPROVALS:

NTEP Class III 3000d,
CC# 97-135A4
CE

EST. SHIP WEIGHT:

8.5 lb (4 kg)

AUTO SHUT-OFF:

Low battery, or after five minutes without use

ACCURACY:

±0.1% of reading

TEMPERATURE:

Operating -4°F to 140°F
(-20°C to 60°C)

NOMINAL OVERLOAD:

200% of capacity

MAXIMUM OVERLOAD:

500% of capacity

WARRANTY:

One-year limited warranty

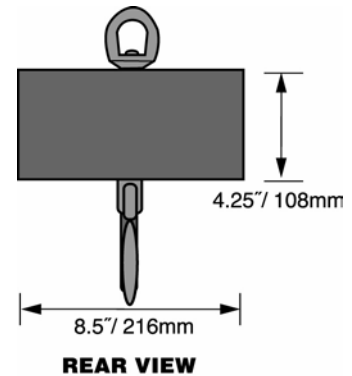

REAR VIEW

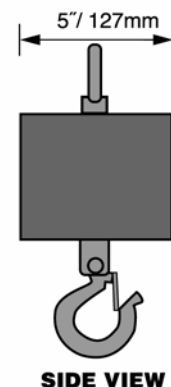

SIDE VIEW

PART #	CAPACITY	GRADUATION	EST. SHIP WEIGHT
82445	25 lb (12.5 kg)	0.01 lb (0.01 kg)	9 lb
82446	50 lb (25 kg)	0.02 lb (0.01 kg)	9 lb
43643	100 lb (50 kg)	0.05 lb (0.02 kg)	9 lb
43644*	300 lb (150 kg)	0.1 lb (0.05 kg)	9 lb
43645*	500 lb (250 kg)	0.2 lb (0.1 kg)	9 lb
43646*	1,000 lb (500 kg)	0.5 lb (0.2 kg)	9 lb

*NTEP Certified